

Industrial Service Bimetal Thermometer (TR Series)

<HSI>

Pressure/ Temperature Instrument

Summary

- 부식성 매체
- 화학, 석유, 식품 산업
- 기계 및 플랜트 엔지니어링
- 배관 및 산업용 난방시설

Standard features

Diameter

50,65,75,100,125,150mm

Accuracy

50,65,75,100,125,150mm : ± 2.0 of Full Scale

Scale Range

50,65,75,100,125,150mm :-50 ~ 650°C

Process connection

50,65,75,100,125,150mm :
PT,PF,NPT - 1/4", 3/8", 1/2", 1"

Material

Case : 304SS

Cover : 304SS

Window : General Glass

Connection : 304SS, 316SS

Stem : 304SS, 316SS

Element : Bimetal Coiled

Pointer : Black Aluminum

TR Series



Pressure Gauge

Temperature Gauge

Temperature Element

Temperature Element

Bimetal Coiled

Common Temperature

75% of Full Scale

Option

Test Report by Manufacturer

Test Report by KOLAS

High Accuracy

OEM Service for a specific customer

Industrial Service Bimetal Thermometer (TR Series)

<HSI>

Pressure/ Temperature Instrument

Type of Mounting

LR Series

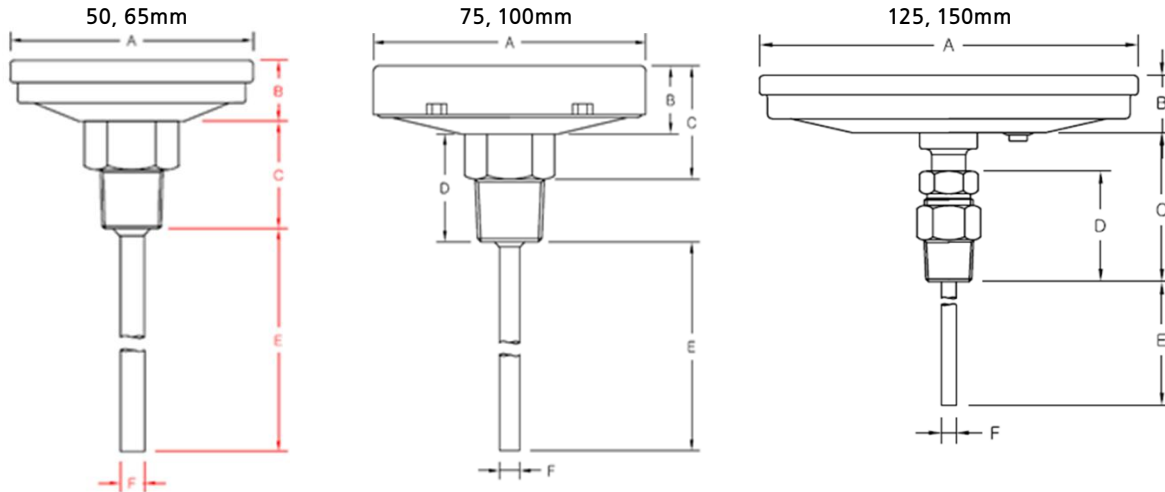

Model	Dial	A	B	C	D	E	F
TR	65	65.0	16.5	29.0	HEX22-36L	Max 1000L	4, 5, 6.4, 8 Standard 6.4ø
	75	84.0	19.5	32.5	HEX24-31L		
	100	111.0	20.0	33.0	HEX24-31L		
	150	164.0	25.0	64.0	48		

온도범위	1눈금 온도	제작가능 최소길이 (6.4ø)					
		50ø	65ø	75ø	100ø	125ø	150ø
0~50℃	1	50	50	50	60	75	155
0~100℃	2	45	45	50	50	60	85
0~150℃	5	30	30	40	40	50	70
0~200℃	5	30	30	30	40	40	60
0~250℃	5	30	30	30	30	45	45
0~300℃	5	50	50	50	50	50	50
0~350℃	5	50	50	50	50	50	50
0~400℃	10	60	60	60	60	60	60
0~500℃	10	60	60	60	60	60	60
0~600℃	10	60	60	60	60	60	60
-50~50℃	2	-	-	50	50	60	85
-30~50℃	2	-	-	50	75	75	95
-30~100℃	5	-	-	40	50	60	80
-20~50℃	2	-	-	50	80	80	100
-20~100℃	2	-	-	35	45	55	75

Pressure Gauge

Temperature Gauge

Temperature Element