

# Euro gauge

## Industrial service pressure gauge

### Model : P252 series

Spec. sheet no. PD02-07

#### Service intended

P252 series are suitable for a corrosive environment. Typical application includes: Chemical, petro-chemical, refining process, power generation, marine and foods industry. Its stainless case and cover have a good appearance and the excellent proof against corrosive and chemical attack.



#### Nominal diameter

63, 80, 100 and 160 mm

#### Accuracy

P2522 (63 mm) and P2523 (80 mm) :  $\pm 1.6$  % of full scale  
P2524 (100 mm) and P2526 (160 mm) :  $\pm 0.5$  % of full scale  
 $\pm 1.0$  % of full scale

#### Scale range (MPa, kPa, bar)

63 and 80 mm : -0.1 ~ 0 to 0 ~ 100 MPa  
100 and 160 mm : -0.1 ~ 0 to 0 ~ 200 MPa

#### Working pressure

Steady : 75 % of full scale (63 and 80 mm)  
100 % of full scale (100 and 160 mm)  
Over range protection : 130 % of full scale

#### Working temperature

Ambient : -40 ~ 65 °C  
Fluid : Max. 200 °C

#### Degree of protection

EN60529/IEC529/IP65

#### Temperature effect

Accuracy at temperature above and below the reference temperature (20 °C) will be effected by approximately  $\pm 0.4$  % per 10 °C of full scale



## Standard features

#### Pressure connection

Stainless steel (316SS)

#### Element

Stainless steel (316SS),  
Model : P2524 (100 mm) and P2526 (160 mm)  
<10 MPa : C type bourdon tube  
 $\geq 10$  MPa : Helical type bourdon tube  
Model : P2522 (63 mm) and P2523 (80 mm)  
<6 MPa : C type bourdon tube  
 $\geq 6$  MPa : Helical type bourdon tube

#### Blowout protection

Back, Rubber disc for 80, 100 and 160 mm  
Top, Rubber disc for 63 mm

#### Case

Stainless steel (304SS)

#### Cover

Stainless steel (304SS)  
Bayonet type

#### Window

Laminated safety glass

#### Movement

Stainless steel

#### Dial

White aluminium with black graduations

#### Pointer

Black painted aluminium alloy

#### Process connection

63 mm :  $\frac{1}{8}$ ",  $\frac{1}{4}$ " PT, NPT and PF  
80 mm :  $\frac{1}{4}$ ",  $\frac{3}{8}$ " PT, NPT and PF  
100 and 160 mm :  $\frac{1}{4}$ ",  $\frac{3}{8}$ ",  $\frac{1}{2}$ " PT, NPT and PF

#### Certificates

Pressure equipment directive (2014/68/EU) Annex III Module H  
ATEX Ex II GD c IIc TX

#### Option

Zero adjustable pointer  
(Only available with diameter 100 and 160 mm)  
Zero adjustment (External) : 100 and 160 mm  
Pressure connection and element : Monel  
(Only available with diameter 100 and 160 mm)

**WISE**<sup>®</sup>

**1. Base model**

**P252** Industrial service pressure gauge

**2. Nominal diameter (mm)**

- 2 63
- 3 80
- 4 100
- 6 160

**3. Type of mounting**

- A** Bottom connection, direct
- B** Bottom connection, surface, case mounting plate
- C** Bottom connection, flush, cover mounting plate
- F** Center back connection, direct, only available with diameter 63 mm
- G** Lower back connection, direct
- H** Center back connection, flush, case center mounting plate, only available with diameter 63 mm
- I** Center back connection, flush, case center mounting plate with bracket only available with diameter 63 mm
- J** Center back connection, flush, cover mounting plate, only available with diameter 63 mm
- L** Lower back connection, flush, case center mounting plate
- M** Lower back connection, flush, case center mounting bracket
- N** Lower back connection, flush, cover mounting plate
- V** Center back connection, flush, cover mounting bracket, only available with diameter 63 mm
- W** Lower back connection, flush, cover mounting bracket

**4. Accuracy**

- 2** ±0.5 % of full scale, only available with diameter 100 and 160 mm, not available with range 0.4 and 0.5 bar
- 3** ±1.0 % of full scale, not available with diameter 63 and 80 mm
- 4** ±1.6 % of full scale, only available with diameter 63 and 80 mm

**5. Process connection**

- B** 1/8"
- C** 1/4"
- D** 3/8", not available with diameter 63 mm
- E** 1/2", not available with diameter 63 and 80 mm

**6. Connection type**

- B** PF
- C** PT
- D** NPT
- F** BSPT
- G** BSP (G)
- Z** Other

**7. Unit**

- H** bar
- I** MPa
- J** kPa
- Z** Other

**8. Range**

**XXX** Refer to pressure unit and range table

**9. Pressure connection material and dial color**

- 3** 316SS and 2 colors
- 4** 316L SS and 2 colors
- 7** 316SS and 3 colors
- 8** 316L SS and 3 colors
- Z** Monel (Only available with diameter 100 and 160 mm)

**10. Option**

- 0** None
- 1** Accessories

**11. Adjustable pointer**

- 0** None
- 1** Zero adjustable pointer
- 2** External zero adjustment

1	2	3	4	5	6	7	8	9	10	11
P252	4	A	3	E	C	H	XXX	3	0	1

Sample  
ordering code

## P252 : Type of mounting (1/3)

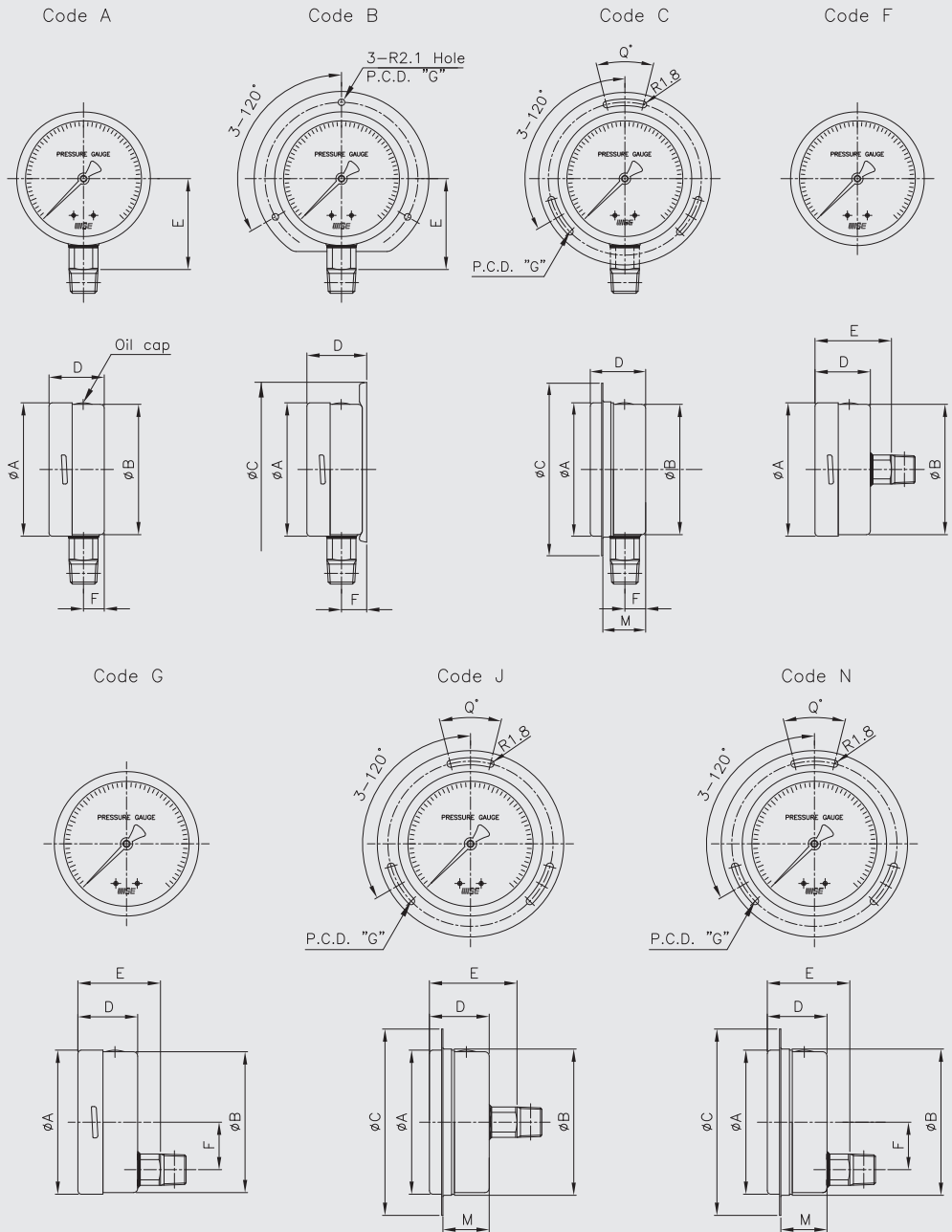

Dimensions (mm)

Dial size	Available code	A	B	C	D±2	E±2	F±1	M	G	H	Q
63	A	64	62		34	41.7	11				
	B	64		85	37	41.7	15		74~75		
	C	64	62	86	34	41.7	11	28	75		15
	F	64	62		34	45					
	G	64	62		34	45	13				
	J	64	66	86	34	45		28	75		15
	N	64	66	86	34	45	13	28	75		15

## P252 : Type of mounting (2/3)

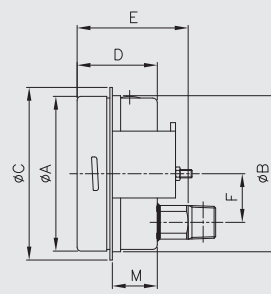
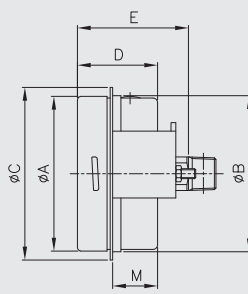
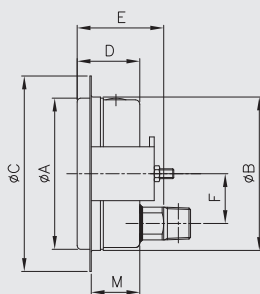
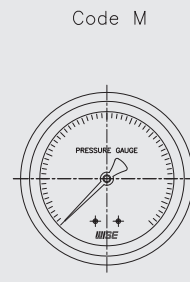
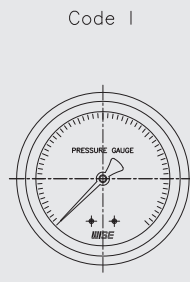
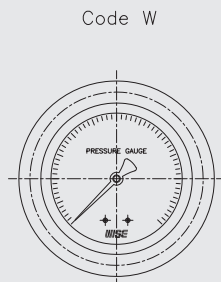
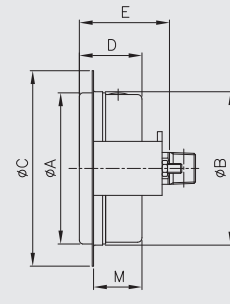
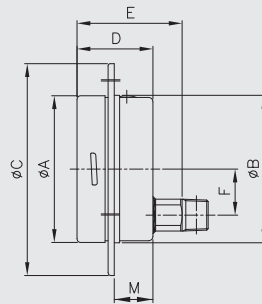
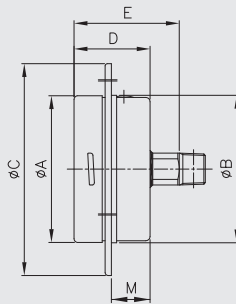
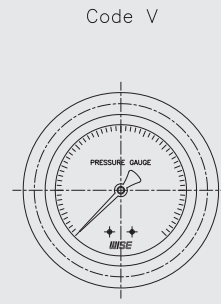
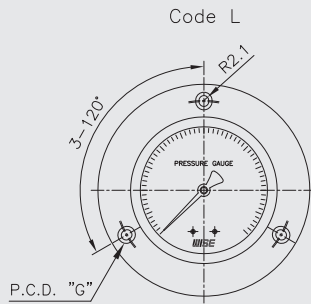
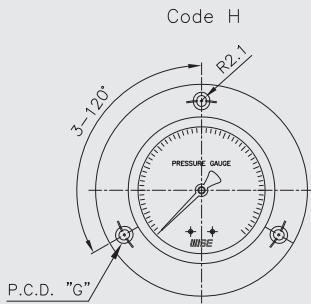

Dimensions (mm)

Dial size	Available code	A	B	C	D±2	E±2	F±1	M	G
63	H	64	64.5	92	34	45		16.8	77~78
	L	64	64.5	92	34	45	13	16.8	77~78
	V	64	66	86	34	45		28	
	W	64	66	86	34	45	13	28	
	I	64	64.5	71	34	45		18.5	
	M	64	64.5	71	34	45	13	18.5	

## P252 : Type of mounting (3/3)

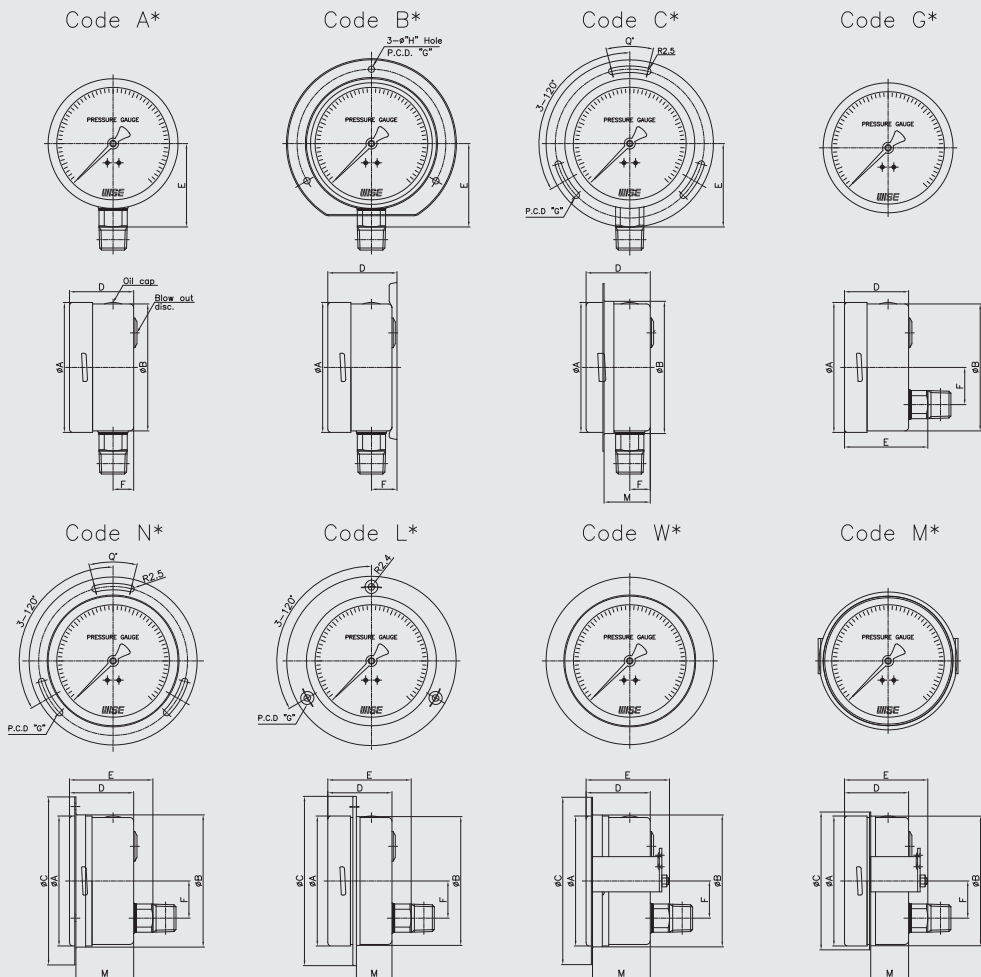

Dial size	Available code	Dimensions (mm)													
		A	B	C	D ±2		E ±2		F ±1		M		G	H	Q
					S.T.D	External	S.T.D	External	S.T.D	External	S.T.D	External			
80	A*	81.2	78.5		39.5	-	50.5	-	12	-					
	B*	81.2		108	43	-	50.5	-	15.5	-			95	5	
	C*	81.2	83.2	108	39.5	-	50.5	-	12	-	35	-	95		10
	G*	81.2	78.5		39.5	-	53.5	-	22	-					
	N*	81.2	83.2	108	39.5	-	53.5	-	22	-	35	-	95		10
	L*	81.2	81.5	112	39.5	-	53.5	-	22	-	21.8	-	94.5~95.5		
	W*	81.2	83.2	108	39.5	-	53.5	-	22	-	35	-			
	M*	81.2	81.5	88	39.5	-	53.5	-	22	-	22.5	-			
100	A*	101.3	99		50	63		65	16	30.6					
	B*	101.3		133	54.4	67.4		65	19.4	34			116	R2.5	
	C*	101.3	103.1	131	50	63		65	16	30.6	45	58	116		28
	G*	101.3	99		50	63		65	78.5		29				
	N*	101.3	103.1	131	50	63		65	78.5		29	45	58	116	
	L*	101.3	101	132	50	63		65	78.5		29	27.7	40.7	115~116	
	W*	101.3	103.1	131	50	63		65	78.5		29	45	58		
	M*	101.3	101	107.5	50	63		65	78.5		29	29.5	42.5		
160	A*	160.6	159		52.5	66		94	15.8	29.3					
	B*	160.6		196	56	69.5		94	19.4	32.9			178	5.8	
	C*	160.6	164	192	52.5	66		94	15.8	29.3	47.5	61	178		18
	G*	160.6	159		52.5	66	67.5	81		29					
	N*	160.6	164	192	52.5	66	67.5	81		29	47.5	61	178		18
	L*	160.6	162	192	52.5	66	67.5	81		29	28	41.5	175.5~176.5		
	W*	160.6	164	172	52.5	66	67.5	81		29	47.5	61			
	M*	160.6	162	172	52.5	66	67.5	81		29	30.8	44.3			

## Pressure unit and range table

Range and code	Unit and code			Nominal diameter			
	H : bar	I : MPa	J : kPa	63 mm	80 mm	100 mm	160 mm
026	-1 ~ 0	-0.1 ~ 0	-100 ~ 0	O	O	O	O
123	0 ~ 0.4	0 ~ 0.04	0 ~ 40	X	X	O	O
040	0 ~ 0.5	0 ~ 0.05	0 ~ 50	X	X	O	O
041	0 ~ 1	0 ~ 0.1	0 ~ 100	O	O	O	O
133	0 ~ 1.6	0 ~ 0.16	0 ~ 160	X	X	O	O
042	0 ~ 2	0 ~ 0.2	0 ~ 200	O	O	O	O
134	0 ~ 2.5	0 ~ 0.25	0 ~ 250	X	X	O	O
043	0 ~ 3	0 ~ 0.3	0 ~ 300	O	O	O	O
044	0 ~ 4	0 ~ 0.4	0 ~ 400	O	O	O	O
045	0 ~ 6	0 ~ 0.6	0 ~ 600	O	O	O	O
047	0 ~ 10	0 ~ 1	0 ~ 1,000	O	O	O	O
050	0 ~ 15	0 ~ 1.5	X	O	O	O	O
143	0 ~ 16	0 ~ 1.6	X	O	O	O	O
051	0 ~ 20	0 ~ 2	X	O	O	O	O
052	0 ~ 25	0 ~ 2.5	X	O	O	O	O
054	0 ~ 35	0 ~ 3.5	X	O	O	O	O
151	0 ~ 40	0 ~ 4	X	O	O	O	O
055	0 ~ 50	0 ~ 5	X	O	O	O	O
056	0 ~ 60	0 ~ 6	X	O	O	O	O
057	0 ~ 70	0 ~ 7	X	O	O	O	O
058	0 ~ 100	0 ~ 10	X	O	O	O	O
059	0 ~ 150	0 ~ 15	X	O	O	O	O
060	0 ~ 160	0 ~ 16	X	O	O	O	O
062	0 ~ 250	0 ~ 25	X	O	O	O	O
064	0 ~ 350	0 ~ 35	X	O	O	O	O
065	0 ~ 400	0 ~ 40	X	O	O	O	O
066	0 ~ 500	0 ~ 50	X	O	O	O	O
067	0 ~ 600	0 ~ 60	X	O	O	O	O
068	0 ~ 700	0 ~ 70	X	O	O	O	O
070	0 ~ 1,000	0 ~ 100	X	O	O	O	O
074	0 ~ 1,600	0 ~ 160	X	X	X	O	O
075	0 ~ 2,000	0 ~ 200	X	X	X	O	O
006	-1 ~ 0.6	-0.1 ~ 0.06	-100 ~ 60	X	X	O	O
027	-1 ~ 1	-0.1 ~ 0.1	-100 ~ 100	O	O	O	O
007	-1 ~ 1.5	-0.1 ~ 0.15	-100 ~ 150	X	X	O	O
028	-1 ~ 2	-0.1 ~ 0.2	-100 ~ 200	O	O	O	O
029	-1 ~ 3	-0.1 ~ 0.3	-100 ~ 300	O	O	O	O
030	-1 ~ 4	-0.1 ~ 0.4	-100 ~ 400	O	O	O	O
010	-1 ~ 5	-0.1 ~ 0.5	-100 ~ 500	O	O	O	O
031	-1 ~ 6	-0.1 ~ 0.6	-100 ~ 600	O	O	O	O
014	-1 ~ 9	-0.1 ~ 0.9	-100 ~ 900	O	O	O	O
032	-1 ~ 10	-0.1 ~ 1	-100 ~ 1,000	O	O	O	O
033	-1 ~ 15	-0.1 ~ 1.5	-100 ~ 1.5MPa	O	O	O	O
034	-1 ~ 20	-0.1 ~ 2	-100 ~ 2MPa	O	O	O	O
017	-1 ~ 24	-0.1 ~ 2.4	-100 ~ 2.4MPa	O	O	O	O
035	-1 ~ 25	-0.1 ~ 2.5	-100 ~ 2.5MPa	O	O	O	O

O : Available X : Not available