

Electric Contact Pressure Gauges (ECP Series)

<HSI>

Pressure/ Temperature Instrument

Summary

- 내식성, 내마모성
- 펌프, 컴프레서 및 레귤레이터
- 정제 및 해양 산업
- 산업 공정의 제어 및 규제
- 플랜트 모니터링 및 전기 회로 전환

Standard features

Diameter

100, 150mm

Accuracy

100, 150mm : $\pm 1.0\%$ of Full Scale

Scale Range

100, 150mm : -0.1 ~ 2 MPa, 0 ~ 100 MPa

Process connection

100mm : PT,PF,NPT - 3/8", 1/2"

150mm : PT,PF,NPT - 1/2"

Material

Case, Cover : STS 304

Window : Poly Carbonate

Connection : STS 316

Element : STS316

Movement : STS304

Contact Rating

AC 125V 0.5A / 250V 0.25A

Connection Diagram

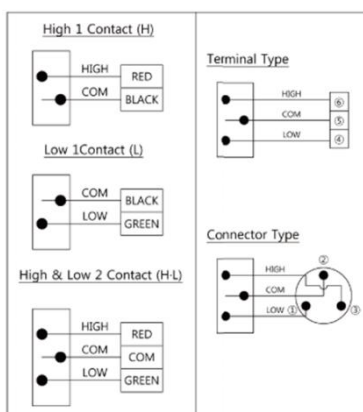

ECP Series (Type A)



Pressure Gauge

Temperature Gauge

Temperature Element

Pressure Limitation

Steady : 3/4 of full scale (75%)

Fluctuating : 3/5 of full scale (60%)

Operating Temperature

Ambient : -20 ~ 65°C

Media(Fluid) : -20 ~ 80°C

Option

Test Report by Manufacturer

Test Report by KOLAS

USE NO OIL

Electric Contact Pressure Gauges (ECP Series)

<HSI>

Pressure/ Temperature Instrument

Type of Mounting

TYPE - A

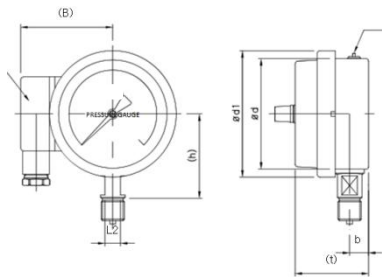

TYPE - B

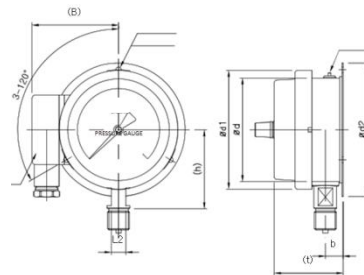

TYPE - D

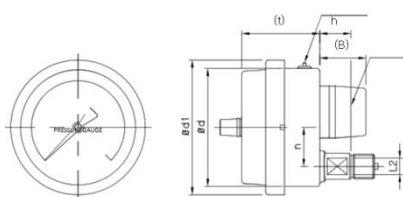

TYPE - BD

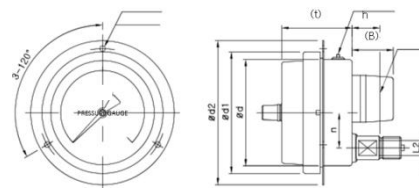

Pressure Gauge

Temperature Gauge

Dial	Model	Ød	Ød1	Ød2	b	n	B	t	L2	h	Øh	Ød
100	A,B	100	114	128	17	-	83	66	17	76	5.5	115
	D,BD			135	-	33	39			26		
150	A,B	77	86	100	14	-	116	66	17	100	5.5	173
	D,BD			107	-	-	39			26		

Temperature Element