

Industrial Service Bimetal Thermometer (LR Series)

<HSI>

Pressure/ Temperature Instrument

Summary

- 부식성 매체
- 화학, 석유, 식품 산업
- 기계 및 플랜트 엔지니어링
- 배관 및 산업용 난방시설

Standard features

Diameter

75,100,150mm

Accuracy

75,100,150mm : ± 2.0 of Full Scale

Scale Range

75,100,150mm : -50 ~ 650°C

Process connection

75,100,150mm : PT,PF,NPT - 1/4", 3/8", 1/2", 1"

Material

Case : 304SS

Cover : 304SS

Window : General Glass

Connection : 304SS, 316SS

Stem : 304SS, 316SS

Element : Bimetal Coiled

Pointer : Black Aluminum

Temperature Element

Bimetal Coiled

LR Series



Common Temperature

75% of Full Scale

Option

Test Report by Manufacturer

Test Report by KOLAS

High Accuracy

OEM Service for a specific customer

Pressure Gauge

Temperature Gauge

Temperature Element

Industrial Service Bimetal Thermometer (LR Series)

<HSI>

Pressure/ Temperature Instrument

Type of Mounting

LR Series

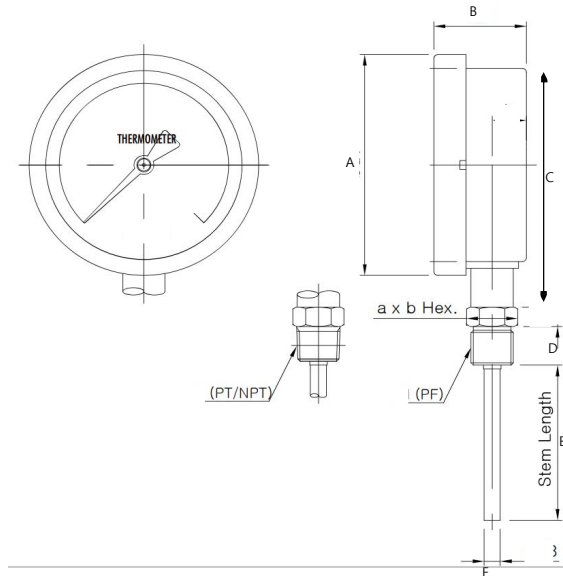

| Model | Dial | A | B | C | D | E | F |
|-------|------|-------|------|-------|---------------|--------------|----------------------------------|
| LR | 75 | 84.0 | 47.0 | 92.0 | HEX 24-30L | Max 1000L | 4, 5, 6.4, 8 Standard 6.4ø |
| | 100 | 110.0 | 49.0 | 123.0 | | | |

| 온도범위 | 1눈금 온도 | 제작가능 최소길이 (6.4ø) | |
|----------|--------|------------------|------|
| | | 75ø | 100ø |
| 0~50℃ | 1 | 60 | 75 |
| 0~100℃ | 2 | 45 | 50 |
| 0~150℃ | 5 | 45 | 40 |
| 0~200℃ | 5 | 30 | 40 |
| 0~250℃ | 5 | 30 | 30 |
| 0~300℃ | 5 | 50 | 50 |
| 0~350℃ | 5 | 50 | 50 |
| 0~400℃ | 10 | 60 | 60 |
| 0~500℃ | 10 | 60 | 60 |
| 0~600℃ | 10 | 60 | 60 |
| -50~50℃ | 2 | 50 | 50 |
| -30~50℃ | 2 | 75 | 75 |
| -30~100℃ | 5 | 50 | 60 |
| -20~50℃ | 2 | 55 | 80 |
| -20~100℃ | 2 | 45 | 55 |

Pressure Gauge

Temperature Gauge

Temperature Element