

Electric Contact Pressure Gauges / DIN (ECP-DIN Series)

<HSI>

Pressure/ Temperature Instrument

Summary

- 내식성, 내마모성
- 펌프, 컴프레서 및 레귤레이터
- 정제 및 해양 산업
- 산업 공정의 제어 및 규제
- 플랜트 모니터링 및 전기 회로 전환

Standard features

Diameter

100, 150mm

Accuracy

100, 150mm : $\pm 1.0\%$ of Full Scale

Scale Range

100, 150mm : -0.1 ~ 2 MPa, 0 ~ 100 MPa

Process connection

100mm : PT,PF,NPT - 3/8", 1/2"

150mm : PT,PF,NPT - 1/2"

Material

Case, Cover : STS 304

Window : Poly Carbonate

Connection : STS 316

Element : STS316

Movement : STS304

Contact Rating

AC 220V 0.7A / 1.0A

Connection Diagram

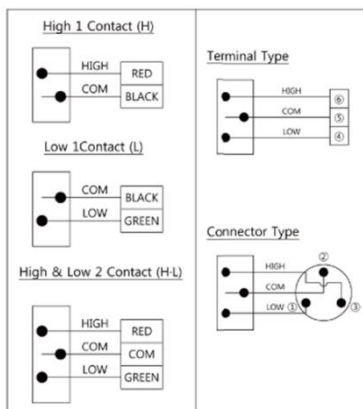

ECP-DIN Series (Type A)



Pressure Gauge

Temperature Gauge

Temperature Element

Pressure Limitation

Steady : 3/4 of full scale (75%)

Fluctuating : 3/5 of full scale (60%)

Operating Temperature

Ambient : -20 ~ 65°C

Media(Fluid) : -20 ~ 80°C

Option

Test Report by Manufacturer

Test Report by KOLAS

USE NO OIL

Electric Contact Pressure Gauges / DIN (ECP-DIN Series)

<HSI>

Pressure/ Temperature Instrument

Type of Mounting

TYPE - A

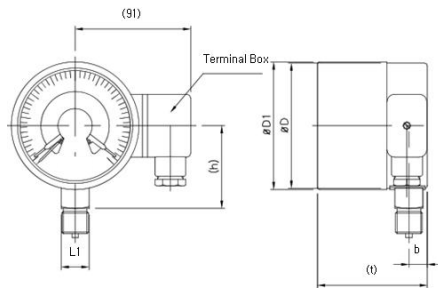

TYPE - B

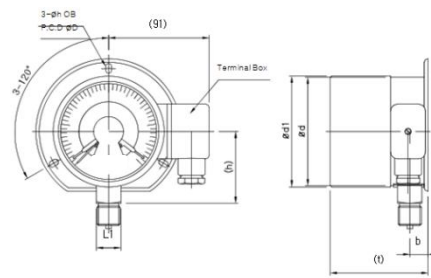

TYPE - D

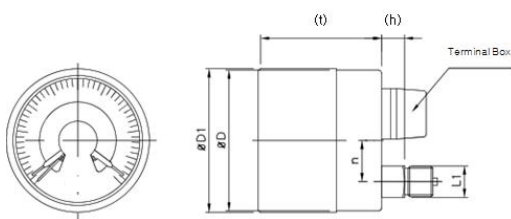

TYPE - BD

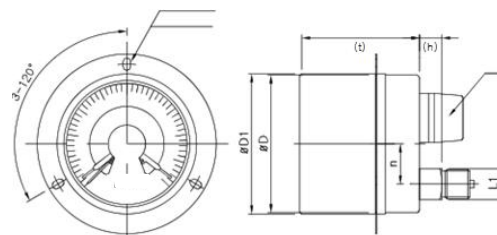

Dial	Model	Ød	Ød1	Ød2	b	n	t	L1	H	Øh	Ød
100	A,B	98.7	100.5	132	17	-	86.5	22	66.5	5.5*8	118
	D,BD				-	33			20.5		

Pressure Gauge

Temperature Gauge

Temperature Element